

# The Worcester CondenseSure

An innovative solution to  
prevent freezing condensate



**NEW**

**WORCESTER**  
Bosch Group

# Prevent freezing condensate pipework with the **CondenseSure** Auxiliary Siphon

With climate change and extreme weather variations becoming increasingly common, and very cold winters with temperatures as low as  $-20^{\circ}\text{C}$  being experienced, installation practices such as externally run condensate discharge pipework are now being questioned.

In the early days of condensing boilers, when the installation standards were being created, there was no great concern that externally routed condensate discharge pipework would present major problems.

Whilst average temperatures have not changed significantly, the extremes of temperatures have. The winter of 2010/2011 was the coldest since accurate records began with the CET (Central England Temperature) for the month of December averaging  $-1^{\circ}\text{C}$ .

Consequently there were many installations that although installed to British Standards, still experienced a frozen condensate pipe with the subsequent interruption to the boiler operation.

The industry has now strengthened and re-enforced the advice on condensate discharge pipe termination, strongly recommending the internal waste system termination route as the most preferable\*.

However if this is not possible, then externally installed and terminated discharge pipework is permissible providing the following criteria are met.

- The pipe should be run internally as far as possible before going externally and the pipe diameter should be increased to a minimum of 30mm ID (typically 32mm OD) before it passes through the wall.
- The external run should be kept as short as possible, taking the most direct and “most vertical” route to the discharge point, with no horizontal sections in which condensate might collect.
- The external pipe should be insulated using suitable waterproof and weatherproof insulation (“Class O” pipe insulation is suitable for this purpose).



During the winter of 2010/2011 temperatures of  $-17^{\circ}\text{C}$  were not uncommon.

\*Please note that internally run condensate drainage pipes in unheated areas such as lofts and garages etc. should also be treated as an external pipe.

## An alternative and **Sure** solution

The CondenseSure auxiliary siphon has been designed to allow a more flexible approach to boiler siting and enable condensate discharge pipes to be installed externally when an internal route is not practical.

The large capacity of the CondenseSure auxiliary siphon increases condensate discharge volume, significantly reducing or even eliminating the risk of freezing.

**CondenseSure has been extensively tested under simulated extreme weather conditions and proved its effectiveness in preventing frozen condensate at -15°C for a sustained period of 48 hours.**



## A **universal fitting** for new and existing installations

Although developed specifically for Worcester Greenstar gas- and oil-fired boilers, the Worcester CondenseSure has the added advantage of being able to be fitted to any make of condensing boiler for both new and retrofit installations. CondenseSure can provide a simple solution which eliminates the need for re-siting both the new boiler and the system pipework when replacing an existing non-condensing appliance. CondenseSure can easily be fitted to existing installations to provide peace of mind in extreme weather conditions.

The CondenseSure insulating jacket helps to retain the temperature of the condensate.

# CondenseSure principle of operation

Within most condensing boilers there is an internal siphon which holds around 100ml of condensate before being released down the condensate discharge pipe. A typical A-rated condensing boiler will generate up to 2 litres of condensate an hour (dependant on



CondenseSure clips onto the 22mm heating flow pipe using the 'free' heat to raise the condensate temperature.

output and temperature) and this will result in the in-built siphon discharging approximately every 3 minutes. With this frequency of discharge it is unlikely that the condensate pipework is ever empty of condensate, consequently increasing the potential for freezing of the pipework in prolonged sub-zero temperatures.

The CondenseSure siphon connects to the boiler condensate discharge outlet and collects the condensate into a larger volume before releasing it into the discharge pipe.

With this expanded siphonic operation, the discharge from the CondenseSure is every 15 to 20 minutes, resulting in:

- Increased velocity and flow rate
- With only 3 to 4 siphonic actions per hour, the condensate pipework is empty for longer
- Significantly decreased or even eliminated freezing potential.

Features	Benefits
No power consumption	No electrical wiring connection or supply needed, meaning zero running costs
No moving parts	No failure of components
Can be installed on new or existing installations	Suitable for any gas- or oil-fired condensing boilers
Can be attached to 22mm heating flow pipework	Uses 'free' energy from the pipe to heat the condensate
Can be installed under the boiler or wall mounted away from the appliance	Flexibility
No electrical connections	No electrician needed
No pipe insulation needed	Cost saving and aesthetically pleasing

Product info	
Part number	7 716 192 746

# Ease of installation

CondenseSure has been designed with ease of installation in mind and is suitable for most boiler applications. For maximum effectiveness it should be installed immediately beneath the boiler where it is clipped on to the boiler's heating flow pipe and connected to its siphonic trap. If this is not practical, CondenseSure can be wall-mounted away from the boiler and connected to a 32mm condensate discharge pipe. However, this will sacrifice the benefit of warming the condensate prior to discharge and therefore slightly reduce its performance.

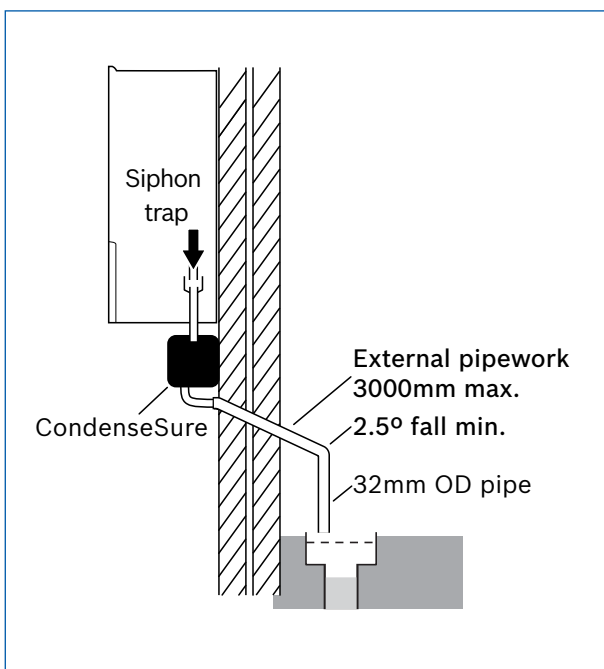

A typical installation using CondenseSure

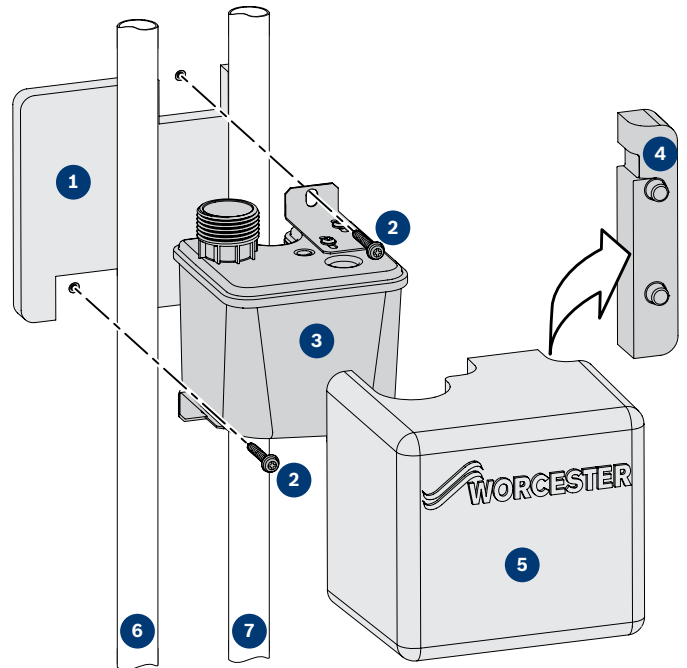

## Fitting to a combi boiler:

1. Foam backing with double-sided tape
2. Siphon mounting screws
3. Siphon body
4. Foam insert (used with regular or system boilers)
5. Foam cover
6. CH flow pipe
7. Boiler DHW outlet pipe

## CondenseSure installation parameters

The CondenseSure will protect an externally run condensate discharge pipe from freezing for 48 hours at -15°C, providing the following installation parameters are met:

- The externally run pipe length does not exceed 3 metres
- There is a fall on the discharge pipe of at least 2.5 degrees
- The discharge pipe diameter is not less than 32mm in diameter.

Whilst it is not necessary to insulate the pipework, it may be a consideration if longer length pipework is required or if lower external temperatures are expected.

Additional installation considerations include:

- Keeping any external pipework as short as possible
- Minimising the number of bends and connections
- Removal of burrs after cutting pipe
- Removal of surplus solvent from the interior of the pipe.

CondenseSure has no working parts to breakdown, does not use any energy and has no electrical connections, so there is no Part P requirement.



**Technical Helpline  
(Pre & Post Sales)**

Tel: 0844 892 3366  
Fax: 01905 752741

**Enquiries**

Email: [service.mailbox@uk.bosch.com](mailto:service.mailbox@uk.bosch.com)  
or telephone 0844 892 3000

**Literature**

Email: [literature@uk.bosch.com](mailto:literature@uk.bosch.com)  
or download instantly from our website  
or telephone 0844 892 9800

[www.worcester-bosch.co.uk](http://www.worcester-bosch.co.uk)



In partnership with



energy saving trust™



Worcester, Bosch Group,  
Cotswold Way, Warndon,  
Worcester, WR4 9SW